



City of Aurora, Ohio - Planning, Zoning and Building Division

129 W. Pioneer Trail, Aurora, OH 44202 330.562.9564 Fax: 330.562.9719 www.auroraoh.com

DECKS

APPLICATION SUBMITTALS

DECKS or other similar structures require submittal of the following:

1. Completed Building Permit Application.
2. A \$62.50 non-refundable deposit. Make checks payable to City of Aurora.
NOTE: *This is an application deposit only. Additional fees may be owed upon issuance of permit.*
3. Two Sets of Plans that include the following:
 - a. Postholes and locations
 - b. Framing plan
 - c. Cross-section showing the posts, depth of footings, framing members, and railing
 - d. **Decks more than 30" high from the ground require a railing.**
4. A Site Plan.
5. Photograph of residence that shows the location of the proposed structure.
6. Approvals necessary prior to issuance of a permit:
 - a. Zoning Inspector
 - b. Plan Review
 - c. Architectural Board of Review (if deck has a roof)**
 - d. Planning, Zoning and Building Division Director
7. All contractors/subcontractors must be registered with the Planning, Zoning & Building Division.
8. Inspections required:
 - a. Posthole
 - b. Framing & Rough Mechanicals
 - c. Final

****Decks with Roofs must be approved by the Architectural Board of Review. ABR meets on the fourth Thursday of each month except for November and December when it meets on the second Thursday of the month. ABR submittal deadline is ten (10) days prior to the meeting.**

3/10/2016

PERMIT # _____
Temporary Permit# _____
Zoning _____



City of Aurora, Ohio - Planning, Zoning and Building Division

129 W. Pioneer Trail, Aurora, OH 44202 330.562.9564 Fax: 330.562.9719 www.auroraoh.com

BUILDING PERMIT APPLICATION FOR DECKS

PLEASE PRINT:

Project Address: _____

Owner's Name: _____ Email: _____

Owner's Address (if different than above): _____

City _____ State _____ Zip Code _____ Phone _____

General Contractor Name: _____

Address: _____ City _____ State _____ Zip Code _____

Phone _____ Cell _____ Email: _____

PROJECT INFORMATION:

Project Cost: \$ _____ Will Deck be 30" or higher above grade: Yes _____ No _____

Height Above Grade _____ Length _____ Width _____ Total Square Footage _____

Electric: Yes _____ No _____ Roof: Yes _____ No _____ Do you have HOA approval? _____

Acceptance of the permit herein applied for shall constitute an agreement on my/our part to abide by all conditions herein contained and to comply with all ordinances of the City of Aurora and the laws of the State of Ohio relating to all work to be done thereunder; and said agreement is a condition of said permit.

Applicant Signature _____
Sign & Print Name _____ Owner/Agent _____

ALL CONTRACTORS/SUBCONTRACTORS MUST BE REGISTERED WITH THE CITY OF AURORA BEFORE PERMITS ARE ISSUED.

NAME AND ADDRESS

GENERAL	_____	CR# _____
EXCAVATOR	_____	CR# _____
MASON	_____	CR# _____
ELECTRICIAN	_____	CR# _____
CARPENTER	_____	CR# _____
CONCRETE	_____	CR# _____
ROOFER	_____	CR# _____
OTHER	_____	CR# _____

(Contractor Registration Number)

IF THE HOMEOWNER IS GOING TO DO ANY/ALL OF THE WORK THEMSELVES, PLEASE FILL IN PAGE 3.

FOR PLANNING, ZONING & BUILDING DIVISION USE ONLY

DATE APPLICATION RECEIVED _____
 RECEIVED BY _____ DEPOSIT AMOUNT **\$62.50**
 PAYMENT: CHECK NO. _____ CASH ___ CREDIT CARD ___
 TEMPORARY PERMIT NO. _____

Res Zoning	\$	25.00*
Res Plan Review	\$	37.50
Res Deck	\$	50.00
Res Occupancy	\$	50.00
Res Comp Dep	\$	300.00*
Other **	\$	_____
Other **	\$	_____
1% State Fee	\$	1.38
SUBTOTAL	\$	463.88
Deposit -	\$	62.50
TOTAL	\$	401.38

PERMIT PAID BY: _____
 ADDRESS: _____

DATE: _____
 CHECK NO. _____
 CASH ___ CREDIT CARD ___
 PERMIT NO. _____

***Do not tax these items.**

**If Other items are added in, such as Electric or Concrete, tax these items and adjust the total taxes.

City of Aurora

PLANNING, ZONING & BUILDING DIVISION
129 W. Pioneer Trail
Aurora, Ohio 44202
330-562-9564 • 330-562-9719 FAX

Date: _____

Property Address: _____

Building Permit Application for _____

I, hereby, acknowledge that I, _____, am the owner of the above stated property. As the property owner, I intend to act as the contractor and/or subcontractor for the following work:

GENERAL	_____	HVAC	_____
EXCAVATING	_____	CONCRETE	_____
SEWER	_____	INSULATION	_____
MASONRY	_____	ROOFING	_____
CARPENTRY	_____	SIDING	_____
PLUMBING	_____	DOWNSPOUTS/GUTTERS	_____
ELECTRICAL	_____	OTHER	_____

As the acting contractor and/or subcontractor, I agree to comply with all the ordinances of the City of Aurora and the laws of the State of Ohio relating to all work to be done and said agreement is a condition of said permit.

Signature of Owner

Date

Print Name

SITE PLAN

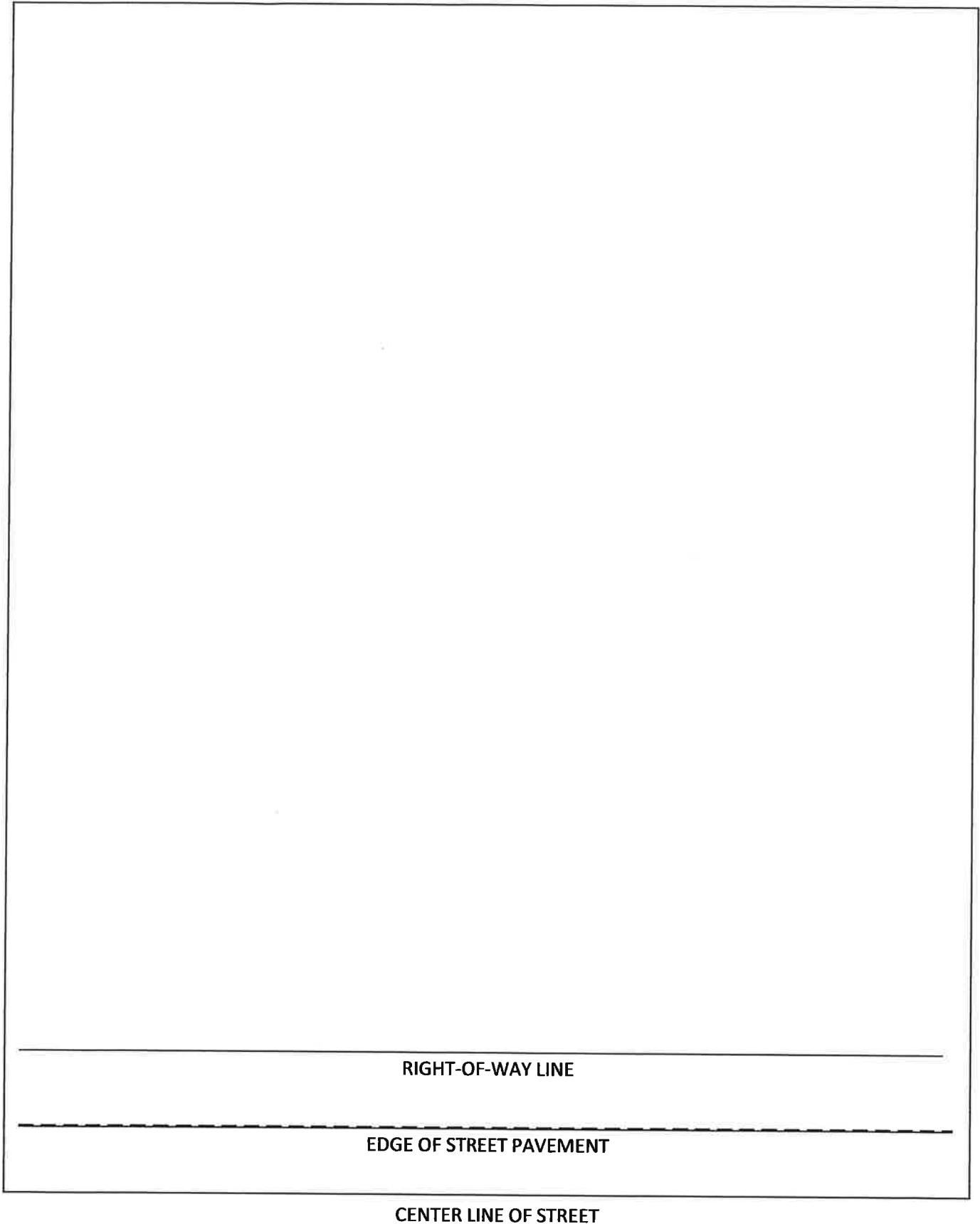

1. SHOW LOCATION OF ALL EXISTING STRUCTURES: HOUSE, GARAGE, DRIVEWAY, ACCESSORY BLDGS., ETC.
2. SHOW LOCATION OF PROPOSED STRUCTURE AND HOW MANY FEET FROM ALL PROPERTY LINES

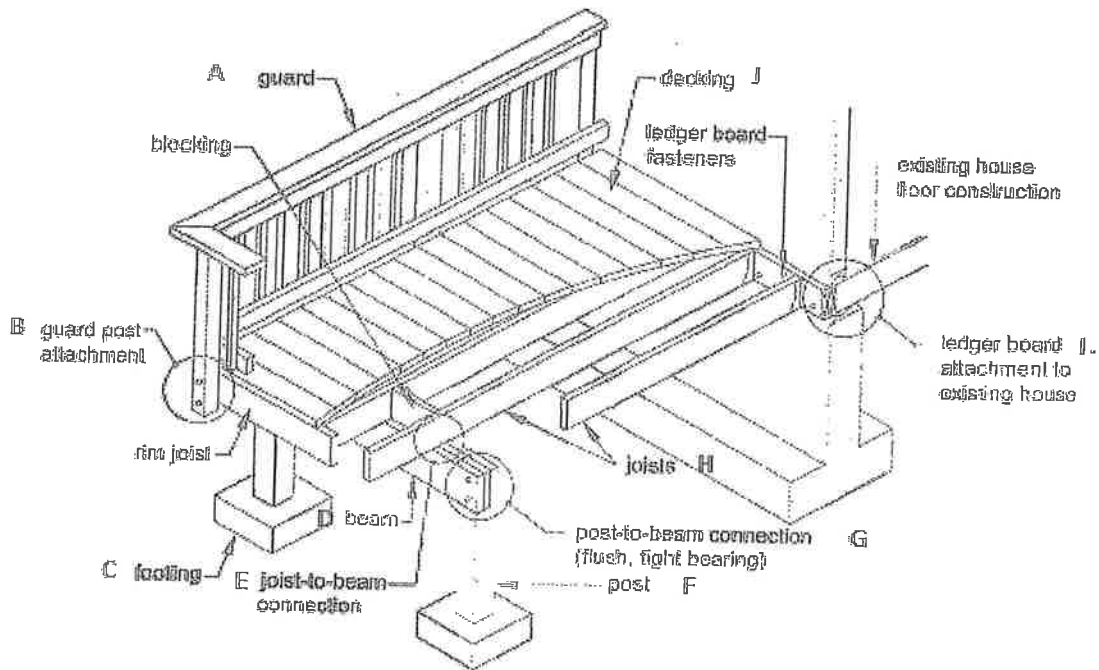

Deck dimensions: _____ x _____

Deck Height above grade: _____

Guards (A):

- Height: _____
- Spacing _____ inches on center

Guard post attachment (B): _____

Footing (C):

- Depth from finish grade _____
- Width _____
- Thickness _____

Beam (D):

- Dimensions _____ x _____
- Span _____
- Cantilever _____

Joist to beam attachment (E): _____

Post (F):

- Dimensions _____ x _____

Post to beam attachment (G):

Joists (H)

- Dimensions _____ x _____
- Span _____
- Spacing _____ inches on center
- Cantilever _____

Ledger Board (I):

- Fastening type _____
- Fastener Size _____ x _____
- Fastener schedule _____

Decking (J):

- Dimensions _____ x _____

Stairs:

- Width _____
- Tread Depth (K) _____
- Riser Height (L) _____
- Number of stringers _____
- Stringer dimension _____ x _____

